



ENTO (Sales Equipment)

102 Henkel Street
Brunswick Vic 3056
AUSTRALIA

Ph: (03) 9380 4944
Fax: (03) 9380 1617
Email: sales@ento.com.au

A proud subsidiary of



B.K. Group Pty Ltd

FLAT BED TROLLEYS



TS/075 & TS/065
Single Deck
(Platform)



TS/080 & TS/070
Double Deck
(2 Tier)



TS/085
Single Deck
Double Ended
Stock Trolley



TS/086
Double Deck
Double Ended
Stock Trolley



TS/090
Single Deck
Double Ended
Stock Trolley
with
Drop Down Sides



TS/072
Single Deck
Double Ended
Stock Trolley



TS/097
Double Ended
Furniture Trolley
6 wheels with side
frame



TS/098 & TS/099
6 wheel platform Trolley



TS/120
Single Deck
Galvanised
Trolley



TS/130
Triple Deck Flat
Galvanised
Trolley



TSM/460GS
Medium Duty - 4
wheel Trolley



TS/005
Single Deck
Tubular Stock
Trolley



TS/055
Double Deck Tubular
Stock Trolley

Six Wheel Sheet Metal Stock Trolley



Constructed from 1.6mm galvanised steel sheet for strength and durability, the flat deck and clean lines make it look good and allows small items to be carried loose on the trolley. Fitted with 200mm fixed centre wheels and 125mm swivel castors to each corner (with this design there is slight light rock from end to end built into the trolley to ensure that the centre wheels are always in contact with the ground). This provides a low push effort and good carrying capacity due to the large centre wheels as well as excellent manoeuvrability because of the swivel castors.

Single Deck (Platform) 6 Wheel Trolley

We have been building trolleys with this basic wheel arrangement since the business started in 1966 and it has been generally accepted as the most suited to the job.

The base is fitted with rubber buffers to front corners. The trolley is available in two sizes as a single or double deck as shown below. The single deck is for heavy load carrying (up to 450kg) and the double deck for stock filling or order picking. The work height of each of these trolleys allows them to do the job with the minimum amount of back strain for the operator. Late in 1992 a series of alterations were made to greatly increase the strength and therefore the life of the trolley as well as improve its appearance. The changes were all completed by early 1993, the most noticeable being the increase in size of the corner castors to 125mm and doubling the thickness of the top deck and inclusion of a buffer on its front corners.



2 Tier (Double Deck) 6 Wheel Trolley

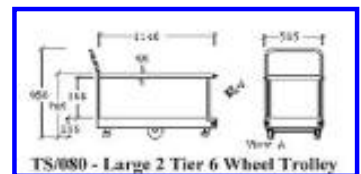
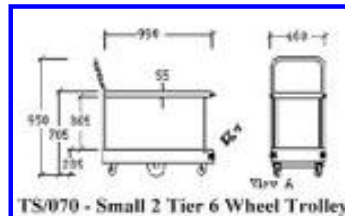
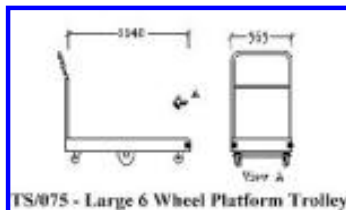
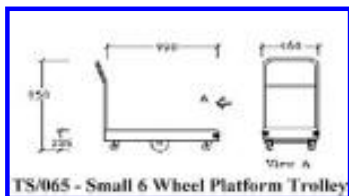

Double Ended Stock Trolleys

The double ended stock trolleys are based on the standard six wheel stock trolleys and are made in different styles in sheet metal and tube. The sheet metal trolley is available in two sizes, the larger one can have drop down sides which can be folded down to form a flat platform or folded up individually to form a bin with three or four sides for bulky or awkward items. The smaller one has two positions for the top deck as shown on the following page. In addition to this, all these models can be fitted with removable top decks making them even more versatile. The designs and sizes are shown here.

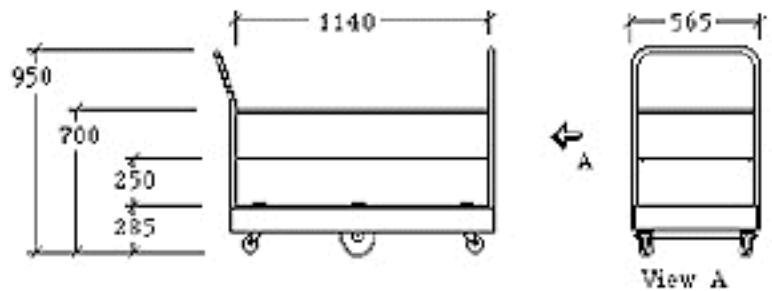

TS/085 - Single Deck Double Ended Stock Trolley



TS/086 - Double Deck Double Ended Stock Trolley



TS/090 - Single Deck Double Ended Stock Trolley with Drop Down Sides

Note: The top for the large trolley (TS/095) is also available as a separate item.

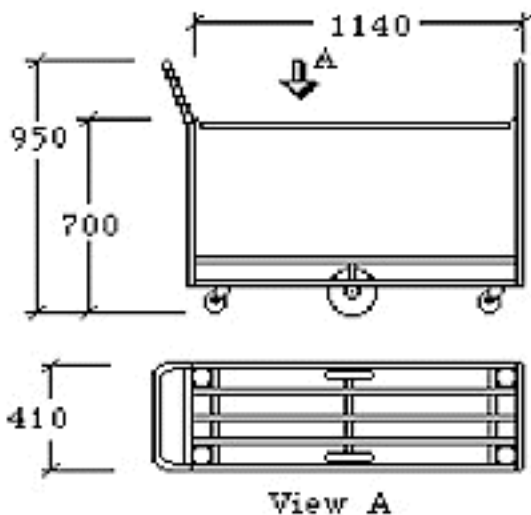

TS/031 - Double Deck Double Ended Tubular Stock Trolley

Note: TS/035 - Double End Tube Top deck is also available as a separate item.

TS/030 - Double ended tube trolley is also available as a separate item.

Most of our stock trolleys are built with the top work area lower than normal work height. This is done to improve stability when the trolley is loaded and to make loading easier by reducing back strain and also so that the contents of the carton that is being worked on is at the correct height. This means that the work surface is low for some tasks such as trimming vegetables when used in the produce department. To overcome this, the double ended trolley shown here has two positions for the top deck, allowing the trolley to be used with the deck removed for moving large amounts of stock or with the deck in either of two positions to give the best height for the job.

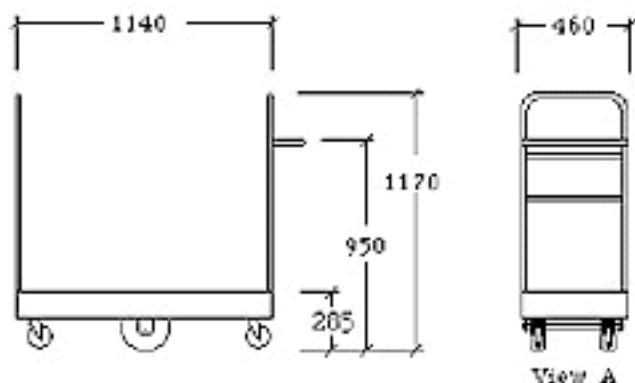

TS/072 - Single Deck Double Ended Stock Trolley

TS/073 - TOP DECK FOR 2 HANDLE TROLLEY 1140x460mm

The top deck for the two handled trolley is supplied as a separate item since it can be removed. This is suspended from the cross bar of the handle, the height of which is shown in the drawing to the right.

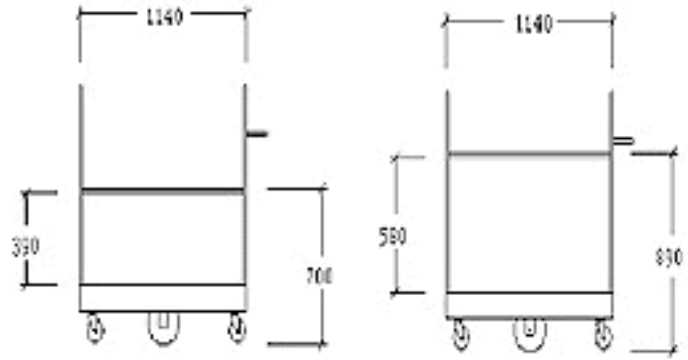

TS/107 - WORK STATION WASTE BIN

The removable waste bin can be fitted to the end of the trolley to take packets and other rubbish such as vegetable scraps when restocking shelves. A polyethylene cutting board can also be supplied so that trimming can be done in the store.

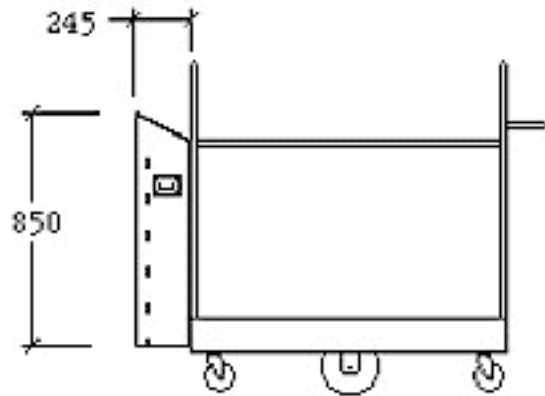

Double Ended Furniture Trolleys

TS/096 TROLLEY - 6 WHEEL FURNITURE - 1140 X 565mm WITH SIDE FRAME

TS/097 TROLLEY - BULKY ITEMS - 1140 X 800mm - 6 WHEEL WITH SIDE FRAME



TS/097 TROLLEY - BULKY ITEMS
1140mm X 800mm
6 wheels with side frame

The Furniture and Bulky Items Trolley are similar to the standard 6 wheel stock trolleys in construction. They have the same style base and the same castor configuration; however, rather than a handle at one end, it has a rail along each to contain long and bulky items such as table tennis tables, beds, mattresses, pack of brooms etc.

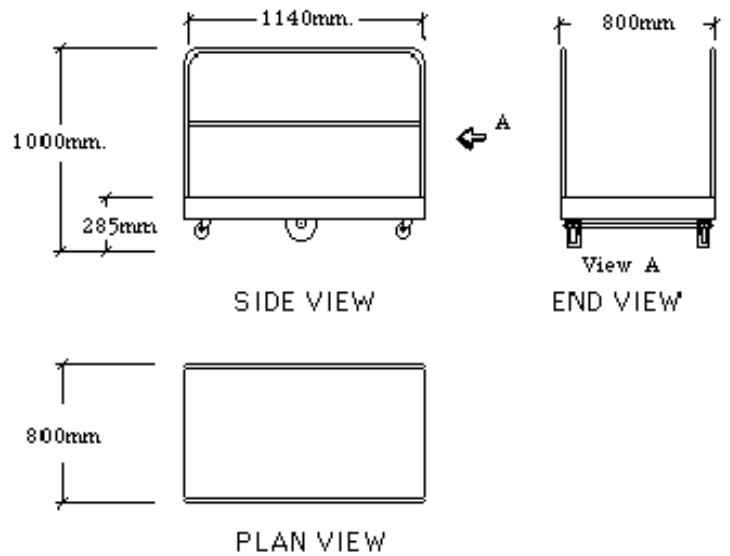

TS/098 TROLLEY - 6 wheel platform 1140x800mm with 2 handles

TS/099 TROLLEY - 6 wheel platform 1220x750mm with 2 handles



TS/098 TROLLEY
6 wheel platform 1140mm x 800mm with 2 handles
TS/099 TROLLEY
6 wheel platform 1220mm x

To cover occasions where a larger trolley is required, these two trolleys are assembled with a 2 handle arrangement like the other double ended trolleys. This

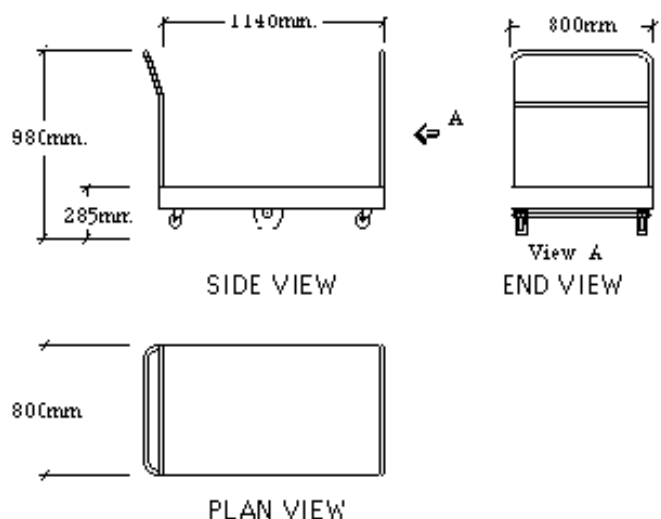

750mm with 2 handles

gives a large platform area with the same ease of movement and handling as the standard trolleys.

4 Wheel Customer Trolleys



TX/021 Basket Trolley

Basket Trolley

Special transport basket style trolley. Used for transporting reams of material on bolts. Style enables wide rolls of material not to fall out.



TS/120 Single Deck Flat Galvanised Trolley
1230mm X 720mm

TS/120 Single Deck Galvanised Trolley

The TS/120 is a 4 wheel version of the 6 wheel stock trolley ([TS/065](#)) for use where a 4 wheel construction is preferred.

The base is fitted with two fixed and two swivel 200mm castors which enable ease of use when loaded.



TS/130 Triple Deck Flat Galvanised Trolley
1230mm X 720mm X
1315mm high

TS/130 Triple Deck Trolley

The TS/130 is modified from the [TS/120](#) (above). Where two extra decks have been added.

The middle shelf is 575mm from the base and the top shelf is 425mm from the middle shelf.

TSM/460GS
TSM/565GS

TROLLEY - MEDIUM DUTY 4 wheel 460x990mm
TROLLEY - MEDIUM DUTY 4 wheel 565x1140mm

This trolley is a medium duty version of the standard six wheel stock trolleys ([TS/065](#) & [TS/075](#)) for use where a 4 wheel construction is preferred. The trolley deck is a modified top deck from the standard trolley so it has all the strengths and features including buffers on the front corners. The base is fitted with 2 fixed and 2 swivel 125mm castors. A top deck can be also manufactured for these trolleys.



TSM/460GS Trolley
Medium Duty - 4 wheel

Note: *This trolley can also be manufactured as a two tier (double deck) trolley or in stainless steel for use in high corrosion areas on request.*

Six Wheel Tubular Trolleys

Constructed from 25.4x1.6mm round steel tube, welded and galvanised or chrome plated for strength and durability. Fitted with 200mm fixed centre wheels and swivel castors to each corner as for the sheet metal trolleys. This gives them all the same handling and load carrying characteristics.

As with the sheet metal trolleys, these are also available in two sizes as a single and double deck. Since their basic design is the same as the sheet metal trolleys, they also have the same features and handling characteristics.



**TS/005 SINGLE DECK TUBULAR
STOCK TROLLEY**
1000x410mm (galvanised)

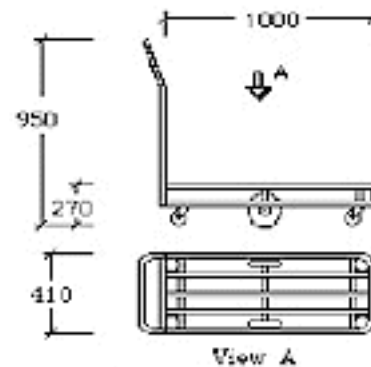

**TS/005 - Single Deck Tubular
Stock Trolley**

**TS/007 SINGLE DECK TUBULAR
STOCK TROLLEY**
1000x410mm (chrome plated)

**TS/015 DOUBLE DECK TUBULAR
STOCK TROLLEY**
1000x410mm (galvanised)

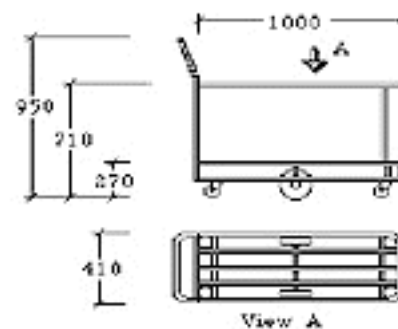

**TS/015 Double Deck Tubular
Stock Trolley**

TS/016 TOP DECK FOR A TS/005
1000x410mm (galvanised)

**TS/045 SINGLE DECK TUBULAR
STOCK TROLLEY
1200x600mm (galvanised)**

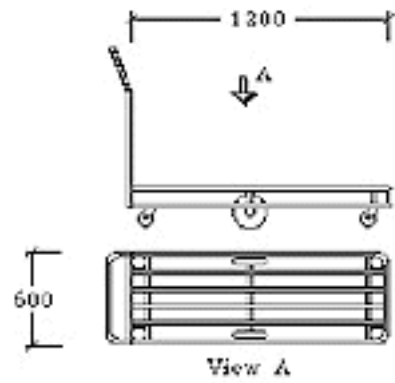

**TS/045 Single Deck Tubular
Stock Trolley**



**TS/055 DOUBLE DECK TUBULAR
STOCK TROLLEY
1200x600mm (galvanised)**

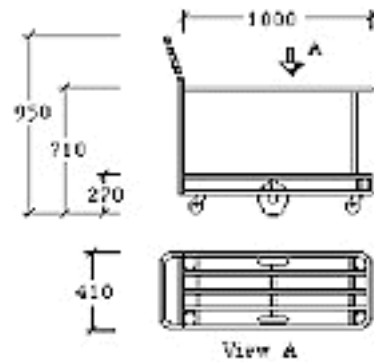

**TS/055 - Double Deck Tubular
Stock Trolley**